



Abbott

HEARTMATE 3™
LEFT VENTRICULAR
ASSIST DEVICE
(LVAD)

PATIENT GUIDE



VIVIAN

HeartMate 3™ LVAD
Recipient

QUICK START GUIDE

This patient guide is for using the HeartMate 3™ Left Ventricular Assist Device (LVAD) that both the patient and caregiver will need to be familiar with upon hospital discharge. Although most of the procedures can be performed by the patient, a caregiver's assistance will be needed in some cases. For more detailed information about monitoring and maintaining the equipment, consult the complete HeartMate 3™ Left Ventricular Assist System Patient Handbook.

WARNINGS AND CAUTIONS

Review all the warnings and cautions in the HeartMate 3 Left Ventricular Assist System Patient Handbook.

WARNINGS refer to actions or hazardous conditions that could cause serious injury or death.

CAUTIONS refer to actions or potentially unsafe conditions that are usually not life-threatening risks but may cause injury, damage the equipment or affect how the system works.

TABLE OF CONTENTS

The HeartMate 3™ LVAD System.....	5
What Should I Know Prior to Hospital Discharge?	6

SYSTEM CONTROLLER

Overview	9
Buttons and User Interface Screen.....	10
User Interface Screen Display.....	11
Lighted Symbols	12
Alarms.....	14
Changes to Backup System Controller – Multiple Sources	18
Changes to Backup System Controller – Single Source	20
Perform a Controller Self Test	22
Driveline Exit Site Care and Stabilization.....	23
Backup Battery	24
Charging the Backup Battery.....	25

POWERING THE SYSTEM

14 V Lithium-ion Batteries.....	27
Universal Battery Charger.....	28
Battery Charger Display Messages	29
Mobile Power Unit (MPU) Overview.....	30
Switching Power Sources	31
MPU Alarms and Troubleshooting	32

ACCESSORIES	35
--------------------------	-----------

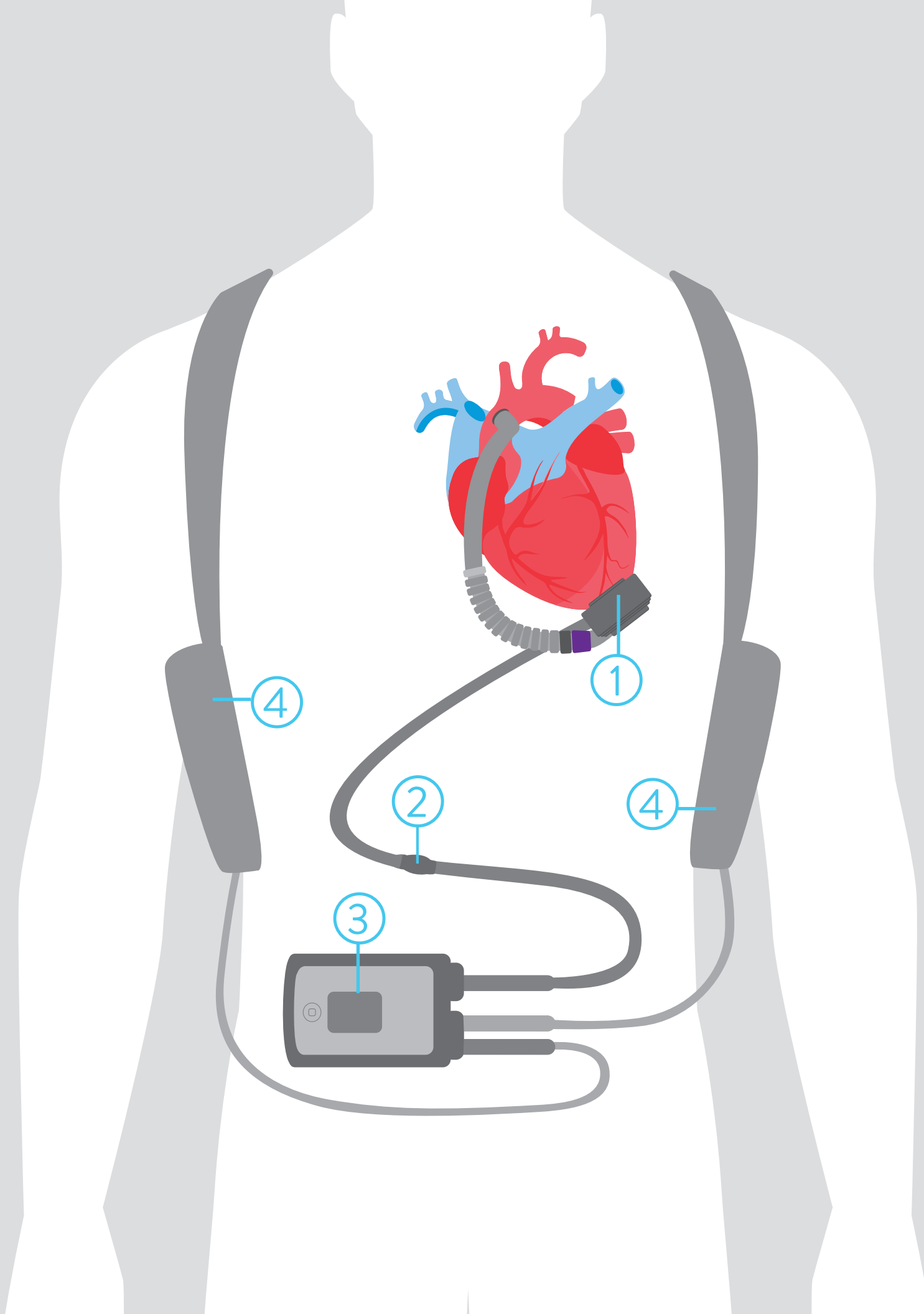

THE HEARTMATE 3™ LVAD SYSTEM

1. HEART PUMP

Connects to the left side of your heart and moves blood from your heart to the rest of your body.

2. DRIVELINE: PAGE 23

Transfers power and information between the controller and the heart pump.

3. SYSTEM CONTROLLER: PAGE 9

Powers and checks the pump and driveline. The controller uses alerts to tell you how the system is working and includes 15 minutes of emergency backup power.

4. BATTERIES AND BATTERY CLIPS: PAGE 27

Powers the system when you are active or outdoors. You always need to use two batteries at a time.

5. BATTERY CHARGER: PAGE 28

Charges up to four 14 V lithium-ion batteries at a time and measures battery charge status.

6. MOBILE POWER UNIT (MPU): PAGE 30

Provides power to the System Controller and pump. Echoes System Controller alarms.



THE HEARTMATE 3™ LVAD SYSTEM: **WHAT SHOULD I KNOW PRIOR TO HOSPITAL DISCHARGE?**

- How to switch the power sources, from MPU to battery to MPU
- How to change the batteries
- How to recharge the batteries
- How to calibrate the batteries
- How to care for the driveline exit site
- How to change the internal MPU battery
- How to change to the backup System Controller (in case of an emergency)

IMPORTANT:

Be sure to keep a backup System Controller and charged batteries with you at all times for use in case of an emergency.

SYSTEM CONTROLLER

SYSTEM CONTROLLER: OVERVIEW

The **System Controller** is a small computer that controls and checks system information. It is connected to the pump via the driveline. It is used to control and respond to system operation. It identifies and warns of any problems in the system operation.

The System Controller consists of control buttons, lighted symbols and a user interface screen.

1. POWER SOURCE CONNECTIONS

2. DRIVELINE CONNECTION

3. CONTROL BUTTONS

- a. Battery button
- b. Display button
- c. Silence alarm button

4. LIGHTED SYMBOLS

- a. Cable disconnect symbols
- b. Status symbols
- c. Pump running symbol

5. USER INTERFACE SCREEN

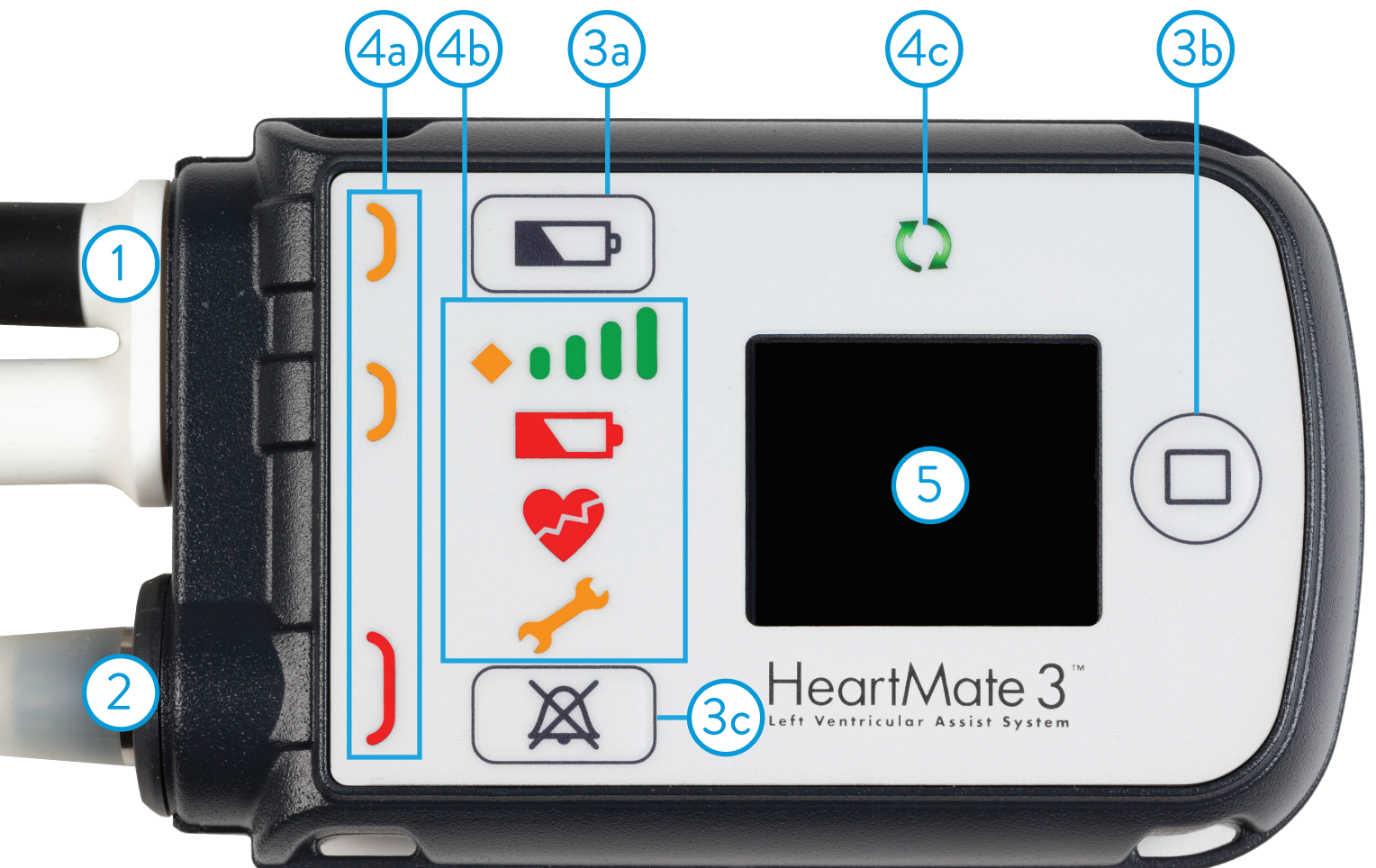

SYSTEM CONTROLLER: BUTTONS AND USER INTERFACE SCREEN

1. BATTERY BUTTON

- Displays the battery power (press and release).
- Tests the controller (press and hold for 5 seconds).
- Puts the controller into sleep mode (press and hold for 5 seconds when nothing is connected to the controller).

2. DISPLAY BUTTON

Activates the user interface screen (press and release) to display information about system operation.

3. SILENCE ALARM BUTTON



- Silences an active alarm (press and release).
- Displays previous alarms (press and release the silence alarm and display buttons simultaneously).

4. USER INTERFACE SCREEN

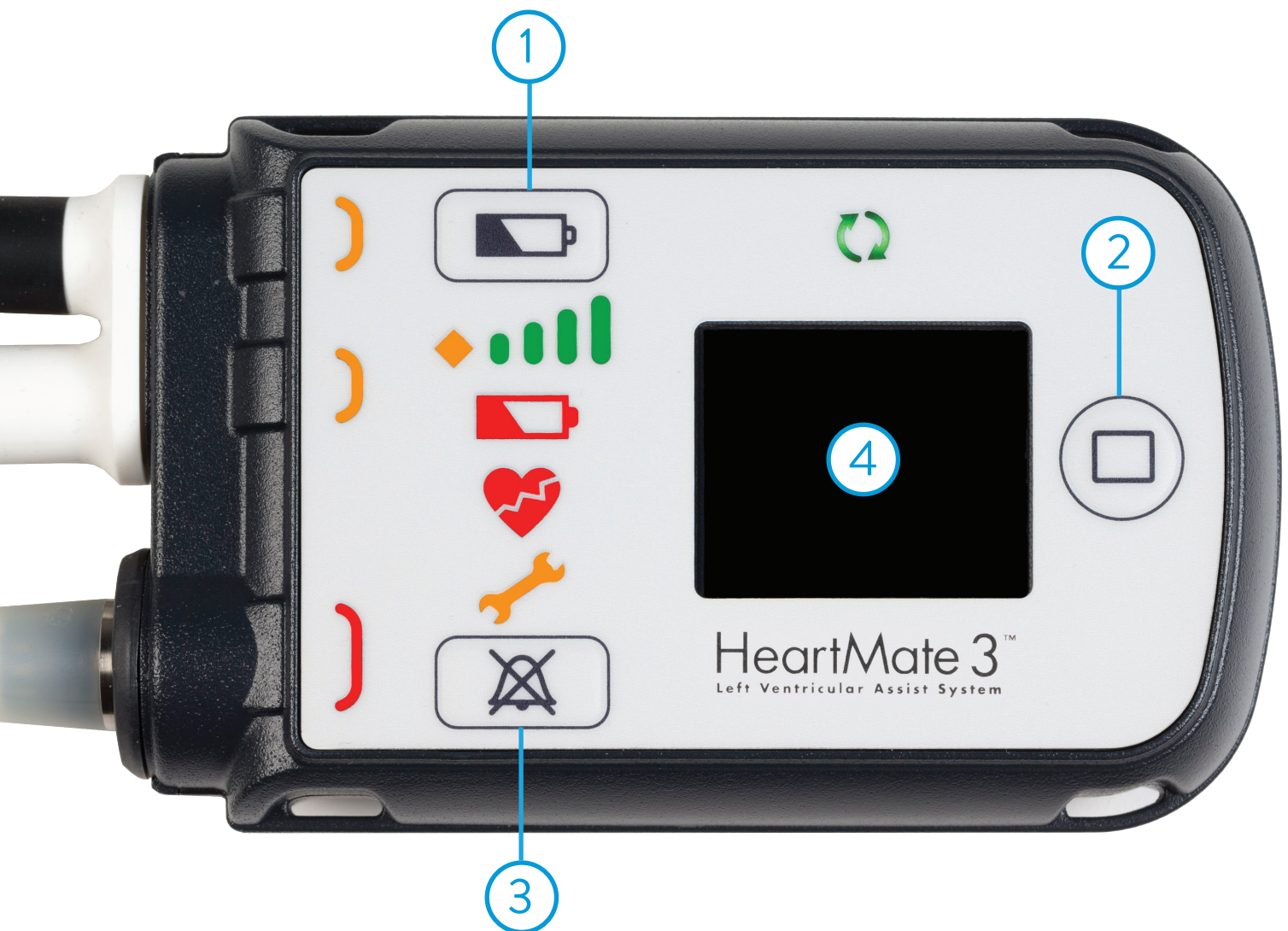
Displays information including pump speed, pump flow, pulsatility index, power and charge status of the backup battery.

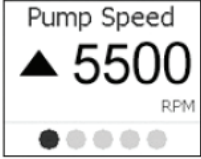
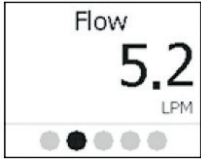
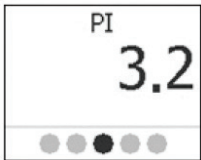
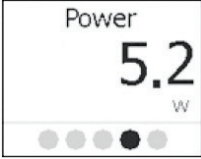
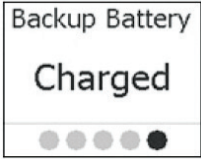

SYSTEM CONTROLLER: USER INTERFACE SCREEN DISPLAY

DISPLAY BUTTON ACTIONS	SCREEN DISPLAYED (EXAMPLE)	MEANING
Press ONCE		Pump speed in revolutions per minute
Press SECOND time		Pump flow in liters per minute
Press THIRD time		Pulsatility index
Press FOURTH time		Power in watts
Press FIFTH time		<p>The System Controller's backup battery (located inside the System Controller and used to temporarily run the pump during an emergency) has three charge status states:</p> <ol style="list-style-type: none"> 1. Charged (ready for use) 2. Charging (actively charging)
Press SIXTH time		Blank user interface screen indicates the screen is off, which is normal

SYSTEM CONTROLLER: LIGHTED SYMBOLS

The System Controller provides information about the system's functioning using lighted symbols on the device. The symbols indicate when the pump is running or when there's a problem with the pump's functioning that needs immediate attention. Other symbols indicate remaining battery power, problems with the connections to the power cable or driveline, or other issues with the system.



YELLOW LIGHT

Near the white or black power cables comes on when a power cable is not well connected with or is disconnected from the System Controller.

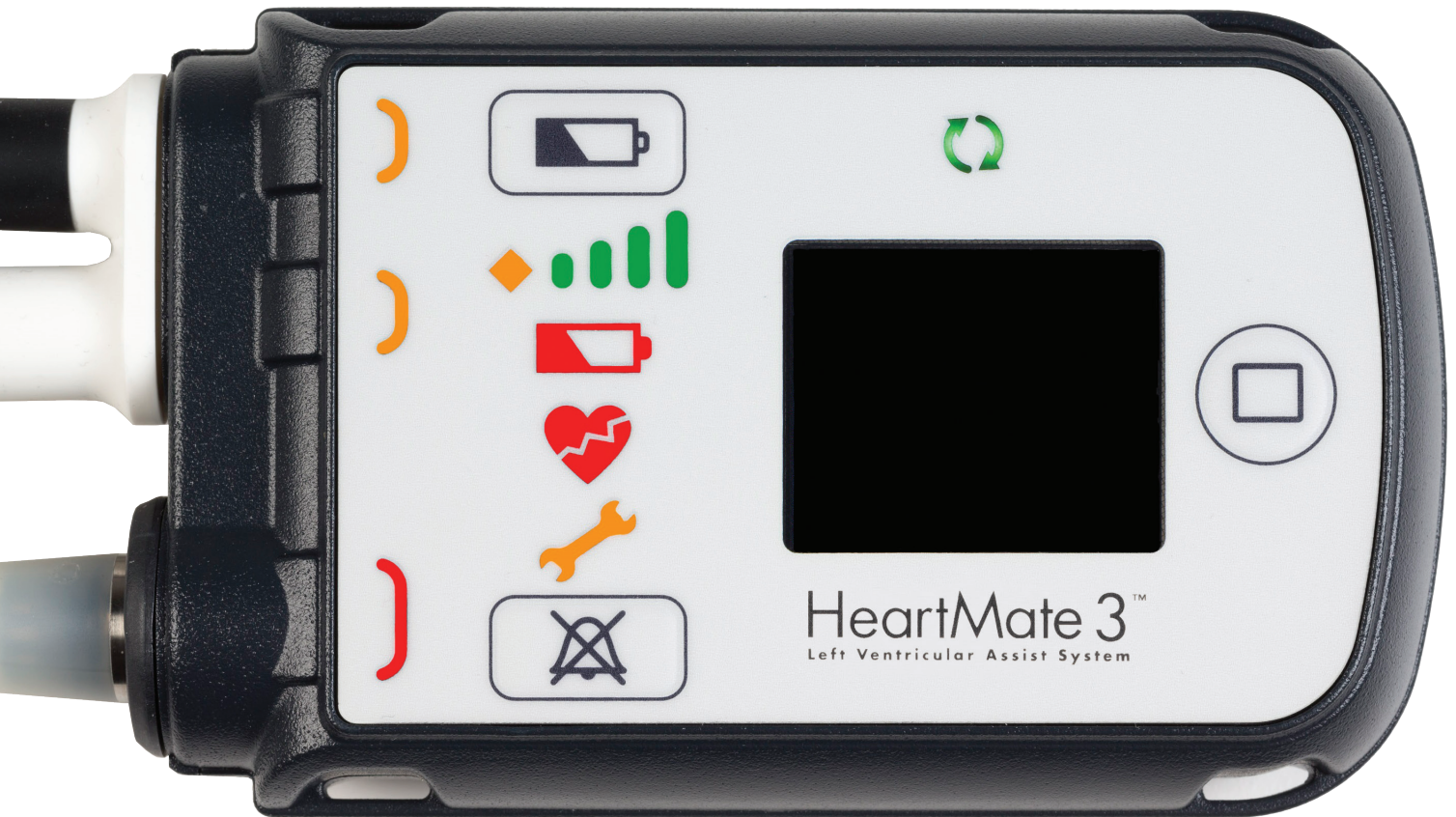

RED LIGHT

Near the driveline connector comes on when the driveline is not well connected with or is disconnected from the System Controller.

SYSTEM CONTROLLER: LIGHTED SYMBOLS



PUMP RUNNING LIGHT

Stays lit green as long as the LVAD is running.



BATTERY CAPACITY LIGHT

4 green lights = Approximately 75%–100% of power remains

3 green lights = Approximately 50%–75% of power remains

2 green lights = Approximately 25%–50% of power remains

1 green light = Less than 25% of power remains

Yellow diamond only = Less than 15 minutes of power remains



LOW BATTERY ALERT

Less than 5 minutes of battery power remain. Immediately replace used batteries with fully charged batteries or switch to the MPU.



HAZARD ALARM

When the red heart symbol comes on, follow the on-screen instructions. Do this immediately.





YELLOW WRENCH

Lights up yellow when the System Controller detects a mechanical, electrical or software issue with the system.

SYSTEM CONTROLLER: ALARMS

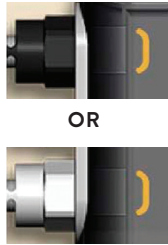

System Controller advisory and hazard alarms are messages that appear on the user interface screen when some problem with the system needs immediate attention. Some of the alarms indicate problems you can address yourself (for example, a disconnected power cable that you should reconnect). But most instruct you to call your hospital contact for instructions.

ADVISORY

SYSTEM CONTROLLER SCREEN	ACTIVE SYMBOLS	ALARM MEANS	TO RESOLVE ALARM
<p>Connect Power</p> <p>⊕ :04</p>		<p>One of two power cables is disconnected</p>	<ol style="list-style-type: none"> 1. Promptly connect the disconnected power cable to the power source (functioning MPU or two fully charged HeartMate 3™ LVAD 14 V lithium-ion batteries). 2. If alarm persists, call your hospital contact.
<p>Replace Power</p> <p>⊕ :02</p> <p>+</p> <p>Low Battery</p> <p>⊕ :06</p>		<p>Low battery, power input is low, with less than 15 minutes remaining</p>	<ol style="list-style-type: none"> 1. Promptly connect to a working or different power source (MPU or two fully charged HeartMate 3 LVAD 14 V lithium-ion batteries). 2. If alarm persists, call your hospital contact.
<p>Call Hospital Contact</p> <p>Controller Fault</p>		<p>System Controller hardware fault</p>	<p>Call your hospital contact as soon as possible for diagnosis and instructions.</p>

SYSTEM CONTROLLER: ALARMS

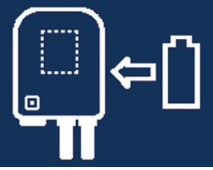











ADVISORY

SYSTEM CONTROLLER SCREEN	ACTIVE SYMBOLS	ALARM MEANS	TO RESOLVE ALARM
<p>Call Hospital Contact</p> <p>Backup Battery Fault</p>		<p>System Controller backup battery fault</p>	<p>Call your hospital contact as soon as possible for diagnosis and instructions.</p>
 <p>+</p> <p>Call Hospital Contact</p> <p>🕒 :07</p>		<p>System Controller backup battery not installed</p>	<p>Call your hospital contact as soon as possible for diagnosis and instructions.</p>

IMPORTANT: The pump running symbol  is always lit green when the pump is running.











SYSTEM CONTROLLER: ALARMS

HAZARD

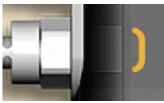
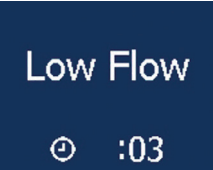
SYSTEM CONTROLLER SCREEN	ACTIVE SYMBOLS	ALARM MEANS	TO RESOLVE ALARM
<p>Low Flow</p> <p>⊖ :03</p> <p>+</p> <p>Call Hospital Contact</p> <p>⊖ :07</p>	 <p>+</p> 	<p>Pump is off.</p> <p>The pump running symbol  is black.</p>	<ol style="list-style-type: none"> 1. Immediately connect to a working power source (MPU or two fully charged HeartMate 3™ LVAD 14 V lithium-ion batteries). 2. If connecting to a power source does not resolve the problem, press any button on the System Controller to attempt a pump start and call your hospital contact immediately.
<p>Connect Power Immediately</p> <p>⊖ :03</p> <p>+</p> <p>Backup Battery</p>  <p>⊖ :07</p>	 <p>+</p>  <p>+</p>  <p>+</p>  <p>+</p> 	<p>Pump has stopped running. MPU power has failed possibly due to static electricity.</p>	<ol style="list-style-type: none"> 1. Immediately connect to HeartMate 3 LVAD 14 V lithium-ion batteries. 2. If restoring power does not resolve, press any button on the System Controller to attempt pump start.
<p>Connect Driveline</p> <p>⊖ :02</p>	 <p>+</p>  <p>+</p> 	<p>Driveline is disconnected.</p> <p>The pump running symbol  is black.</p>	<ol style="list-style-type: none"> 1. Immediately reconnect the driveline to the System Controller and move the driveline safety tab on the System Controller to the locked position. 2. If alarm persists after reconnecting the driveline, press any button on the System Controller to potentially resolve. 3. If driveline is connected and alarm persists, replace System Controller with a programmed backup System Controller. 4. If alarm persists, call your hospital contact immediately.

SYSTEM CONTROLLER: ALARMS

HAZARD

SYSTEM CONTROLLER SCREEN	ACTIVE SYMBOLS	ALARM MEANS	TO RESOLVE ALARM
<p>Backup Battery</p>  <p>+ Connect Power Immediately</p> 	 <p>+</p>  <p>+</p> 	<p>Both power cables are disconnected.</p>	<ol style="list-style-type: none"> 1. Immediately connect to a working power source (MPU or two fully charged HeartMate 3™ LVAD 14 V lithium-ion batteries). 2. If alarm persists, call your hospital contact immediately.
<p>Low Flow</p>  <p>+ Call Hospital Contact</p> 		<p>Low flow: Flow is less than 2.5 liters per minute.</p>	<p>Call your hospital contact immediately for diagnosis and instructions.</p>
<p>Replace Power Immediately</p>  <p>+ Low Battery</p> 		<p>Low voltage: Power input is extremely low, with less than 5 minutes remaining.</p>	<ol style="list-style-type: none"> 1. Immediately connect to a working power source (MPU or two fully charged HeartMate 3 LVAD 14 V lithium-ion batteries). 2. If alarm persists, call your hospital contact immediately.

SYSTEM CONTROLLER: CHANGES TO BACKUP SYSTEM CONTROLLER – MULTIPLE SOURCES

Replace the running System Controller with the backup controller and *multiple available* power sources.

1. SET UP

This procedure will require assistance from a caregiver.

1. Place the backup System Controller within reach.
2. Ensure the patient is sitting or lying down, as he or she may get dizzy if the pump stops briefly.
3. Unlock the driveline safety tab for both controllers (see the image below).



CAUTION:

Do NOT attempt to change your System Controller without having a trained, competent caregiver at your side to assist. Follow all alarm instructions, including calling the hospital. Always contact your LVAD center before changing System Controllers.

SYSTEM CONTROLLER: CHANGES TO BACKUP SYSTEM CONTROLLER – MULTIPLE SOURCES

Replace the running System Controller with the backup controller and *multiple available* power sources.

2. REPLACE SYSTEM CONTROLLER

Important: Keep the running System Controller connected to power.

1. Connect the white and black connectors on the **backup System Controller** to power.

A. Align the driveline arrow/alignment mark with the arrow on the controller.



2. Promptly move the driveline from the running controller to the backup controller (see steps A–C below).
3. Make sure that the green pump running symbol  on the backup System Controller is illuminated.

B. Push the red button and firmly insert the driveline until it snaps into place.



C. Slide the safety tab over the red button.



Important: If the safety tab does not slide fully over the red button, the driveline is not connected. Disconnect the driveline and reconnect it.

3. FINISH

1. Put the old, replaced System Controller into sleep mode by disconnecting from the power, and then pressing and holding the battery button for 5 seconds.

2. Do not use the old System Controller ever again. To request a new backup System Controller and for instructions on returning the old one, contact the hospital.

SYSTEM CONTROLLER: CHANGES TO BACKUP SYSTEM CONTROLLER – SINGLE SOURCE

Replace the running System Controller with the backup controller and a *single available* power source (exchange while on MPU or batteries only).

1. SET UP

This procedure will require assistance from a caregiver.

1. Place the backup System Controller within reach.
2. Ensure the patient is sitting or lying down, as he or she may get dizzy if the pump stops briefly.
3. Unlock the driveline safety tab for both controllers (see the image below).



CAUTION:

Do NOT attempt to change your System Controller without having a trained, competent caregiver at your side to assist. Follow all alarm instructions, including calling the hospital. Always contact your LVAD center before changing System Controllers.

SYSTEM CONTROLLER: CHANGES TO BACKUP SYSTEM CONTROLLER – SINGLE SOURCE

Replace the running System Controller with the backup controller and a *single available* power source.

2. REPLACE SYSTEM CONTROLLER

1. Move the white connector's power source from the running controller to the backup System Controller.
2. Promptly move the driveline from the running controller to the backup controller (see steps A–C below).
3. Make sure that the green pump running symbol  on the backup controller is illuminated.
4. Move the black connector's power source from the running System Controller to the backup controller.

A. Align the driveline arrow/alignment mark with the arrow on the controller.



B. Push the red button and firmly insert the driveline until it snaps into place.



C. Slide the safety tab over the red button.



Important: If the safety tab does not slide fully over the red button, the driveline is not connected. Disconnect the driveline and reconnect it.

3. FINISH

1. Put the old, replaced System Controller into sleep mode by disconnecting from the power, and then pressing and holding the battery button for 5 seconds.
2. Do not use the old System Controller ever again. To request a new backup System Controller and for instructions on returning the old one, contact the hospital.

SYSTEM CONTROLLER: PERFORM A CONTROLLER SELF TEST

Perform a System Controller self test every day to check the audible and visual alarm indicators on the user interface. The System Controller self test is a loud, bright function. All the audible and visual indicators should come on and “Self Test” should appear on the screen.

To perform a System Controller self test:

1. Press and hold the battery button  for 5 seconds.
2. Check that:
 - “Self Test” appears on the screen.
 - All symbols and indicators on the user interface illuminate at the same time.
 - System Controller is making a loud, steady, audible alarm tone.

3. Release the battery button . All the audible indicators/lights should remain on for 15 seconds, after which the audible indicators/lights stop, the screen goes black and the self test is complete.

IMPORTANT:

If an alarm occurs during a self test, the self test terminates and the alarm’s on-screen indicator remains active. A System Controller self test cannot be initiated during the following alarms: any hazard alarm, power cable disconnected advisory alarm or low battery power advisory alarm.



SYSTEM CONTROLLER: DRIVELINE EXIT SITE CARE AND STABILIZATION

It is very important to keep the driveline exit site (where the driveline goes through the skin) clean and dry at all times. Keeping the exit site clean and dry lowers your risk for infection. After leaving the hospital, you are responsible for caring for the exit site. Be sure to always follow the steps provided by your nurse or hospital contact. A driveline management system, supplied by the implanting

center, should be used at all times. The driveline management system should consist of a dressing and stabilizer.

If you notice any signs of infection, call your hospital contact right away. Do not wait! Early treatment makes a difference.

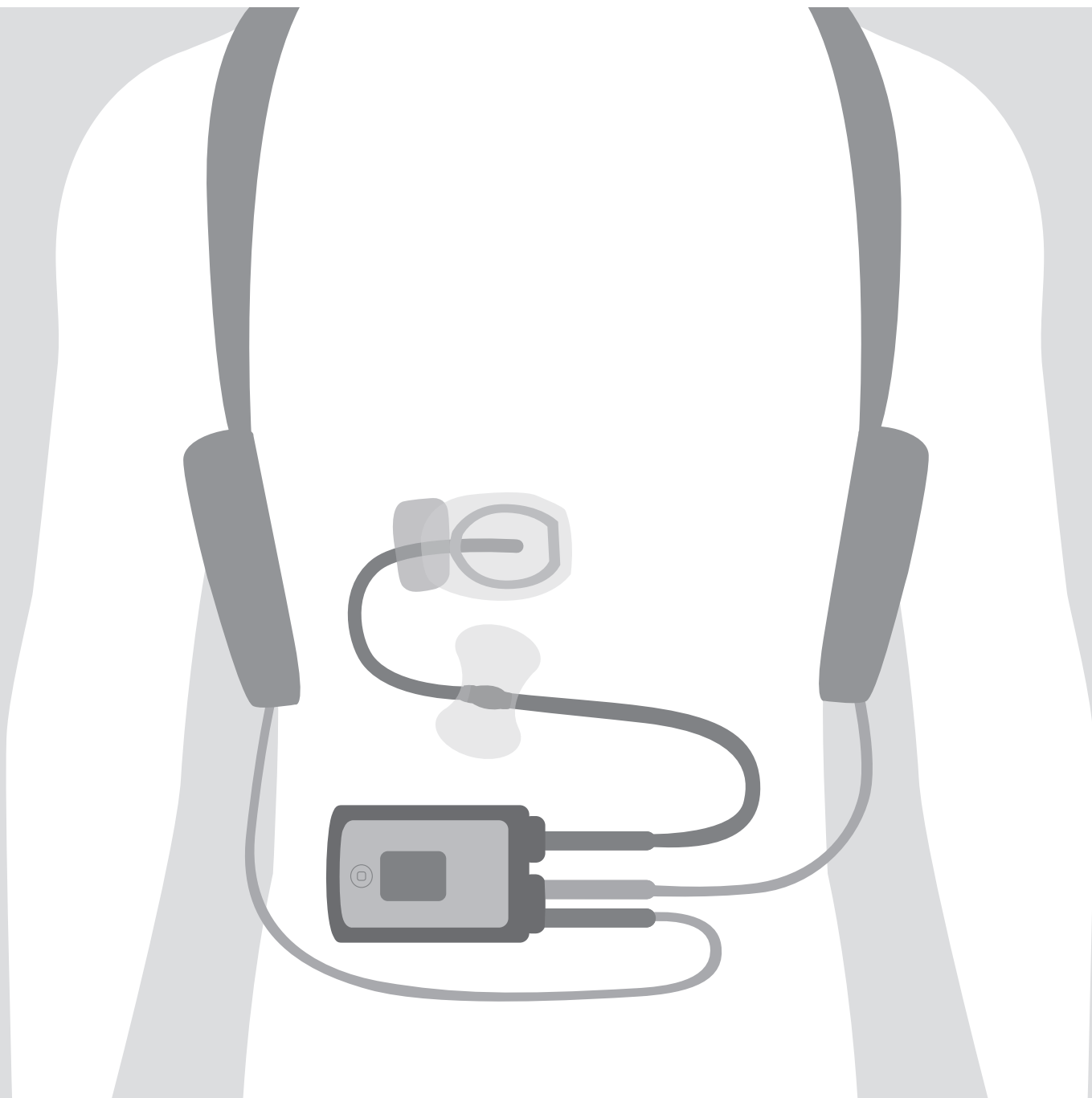

SYSTEM CONTROLLER: **BACKUP BATTERY**

An 11 V lithium-ion backup battery inside the **System Controller** provides at least 15 minutes of backup power to the LVAD if the in-use power source is disconnected or fails.

The System Controller's backup battery will be charged once external power is connected to the System Controller (batteries or MPU).

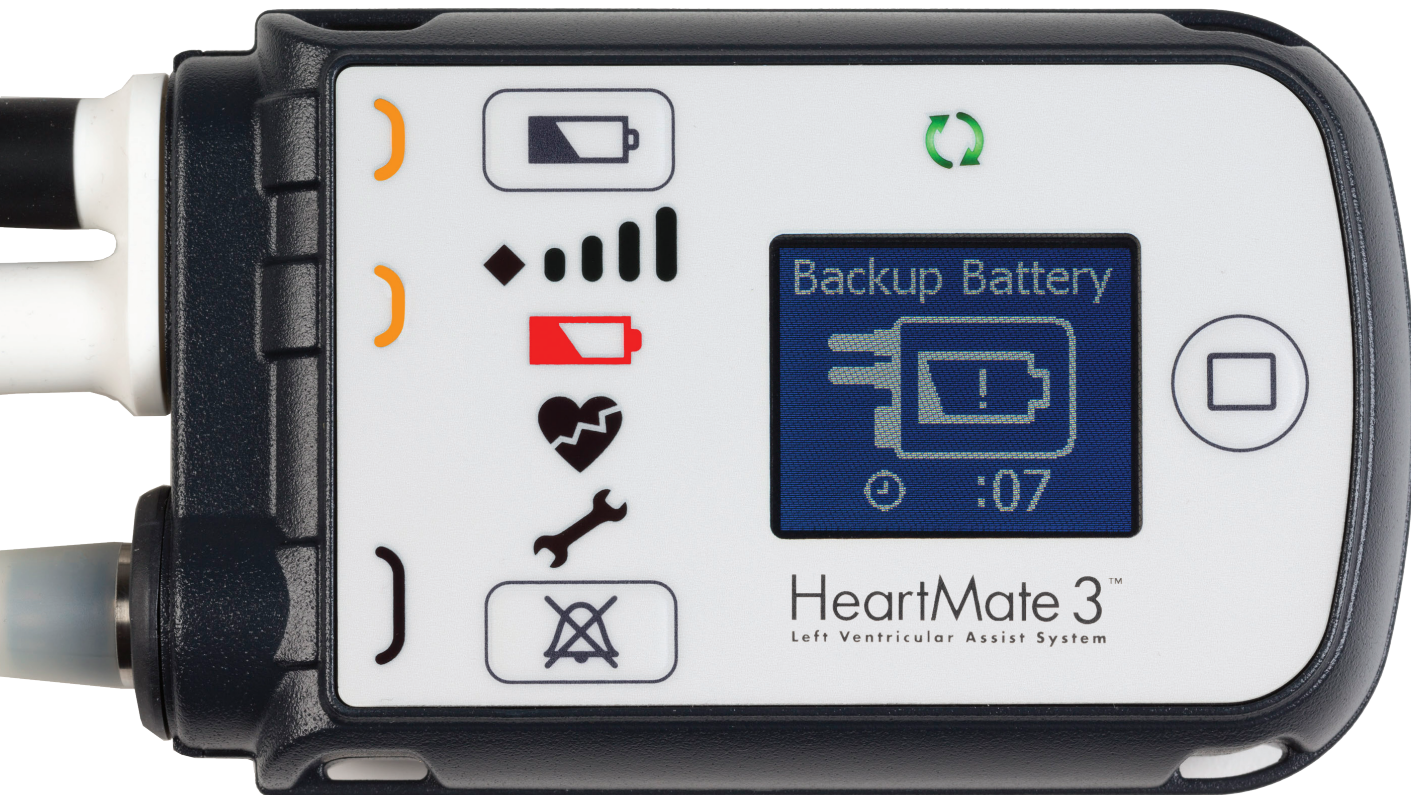

WARNING:

The 11 V lithium-ion backup battery should be used only for temporary support during a power-loss emergency. Inappropriate use of this backup battery may result in diminished run time during a power-loss emergency.

SYSTEM CONTROLLER: CHARGING THE BACKUP BATTERY

Charge the backup battery *inside* the backup System Controller.

1. Connect the backup System Controller to a power source (MPU or two HeartMate 3™ LVAD 14 V lithium-ion batteries).
2. When the System Controller is connected to power, the user interface screen displays “Charging” or “Charging Complete.”
3. When charging is complete, perform a self test on the backup System Controller (press and hold the battery button for 5 seconds).
4. Disconnect power from the backup System Controller. Place the backup System Controller back in the protective case. No further action is needed for 6 months.



CAUTION:

The 11 V lithium-ion backup battery inside the backup System Controller must be charged once every 6 months.



IMPORTANT:

Do not remove power until “Charging Complete” is displayed. It can take up to 3 hours to charge the System Controller’s backup battery.

POWERING THE SYSTEM

POWERING THE SYSTEM: 14 V LITHIUM-ION BATTERIES

The HeartMate 3™ LVAD uses 14 V lithium-ion batteries that provide up to 17 hours of support. They require 4 hours to charge. Five lights on each battery indicate the amount of power remaining in the battery.

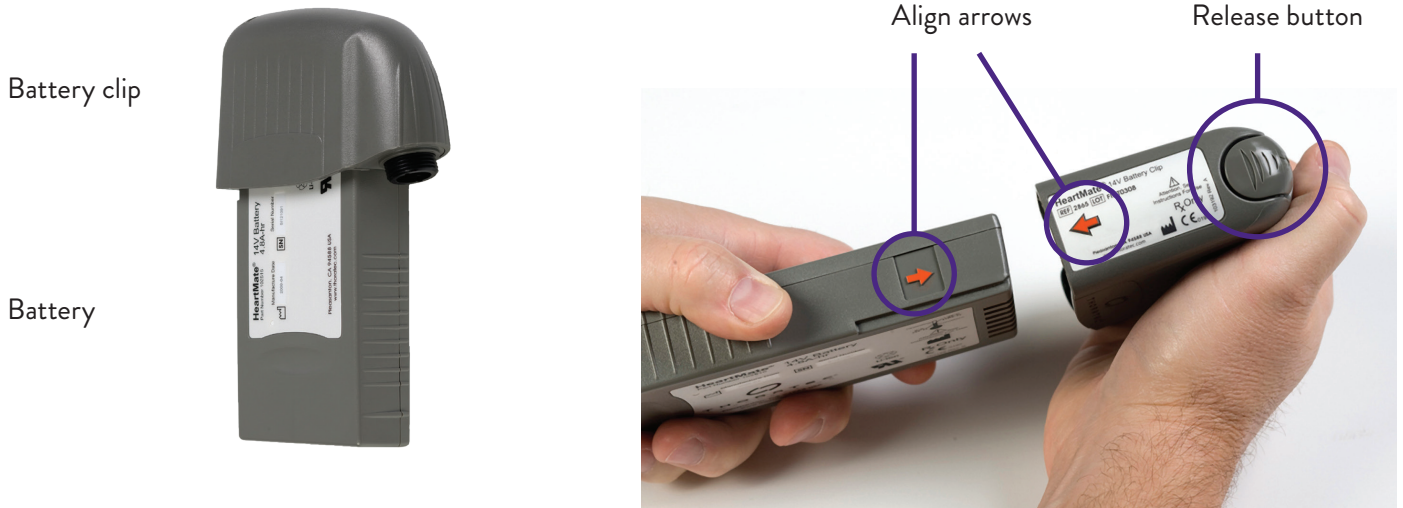

SUPPORT TIME

10–17 hours

CHARGING TIME

4 hours



NUMBER OF LIGHTS ILLUMINATED	MEANING
● ● ● ● ● 5 lights	Approximately 80%–100% of power remains
● ● ● ● ○ 4 lights	Approximately 60%–80% of power remains
● ● ● ○ ○ 3 lights	Approximately 40%–60% of power remains
● ● ○ ○ ○ 2 lights	Approximately 20%–40% of power remains
● ○ ○ ○ ○ 1 light steady	Approximately 10%–20% of power remains
⚡ ○ ○ ○ ○ ○ 1 light blinking	Approximately 10% or less of power remains. Do not use if battery has one blinking light. The HeartMate 3 LVAD System Controller will indicate a power advisory

POWERING THE SYSTEM: UNIVERSAL BATTERY CHARGER



BATTERY CHARGER DISPLAY



Slot number and
LED indicators

LED INDICATORS

LED LIGHT COLOR

STATUS/MEANING



Green

Battery is charged and ready for use.



Yellow

Battery is undergoing test, charging or calibration.



Yellow **blinking**

Battery requires calibration cycle (see the example on the next page).



Red

Battery or charging system is defective. **DO NOT USE BATTERY.**

POWERING THE SYSTEM: BATTERY CHARGER DISPLAY MESSAGES



MESSAGES GENERATED BY PRESSING THE SLOT NUMBER

Available power



Cycle count and charger capacity



AUTOMATIC MESSAGES

Call hospital for service



For example, slot 4
needs calibration



Press 4



Calibration is in progress
for 12 hours



POWERING THE SYSTEM: MOBILE POWER UNIT (MPU) OVERVIEW

The MPU plugs into an AC outlet to provide power to the HeartMate 3™ LVAD System and is used while indoors, stationary or sleeping. The MPU transfers power to the System Controller through the patient cable.

1. SPEAKERS

Sound alarm in case of system problems that need attention.

2. AC POWER RECEPTACLE

For plugging unit into AC power outlet.

3. STATUS SYMBOLS

Provide information about the system status.

4. PATIENT CABLE

Connects to the System Controller to transfer power.



POWERING THE SYSTEM: SWITCHING POWER SOURCES

FROM MPU TO BATTERIES

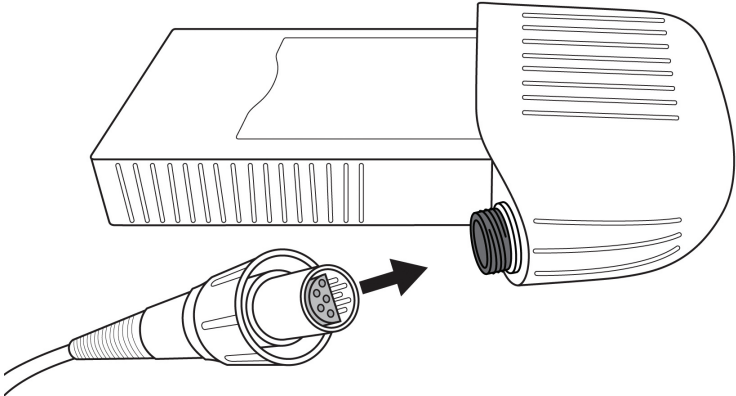

FROM BATTERIES TO MPU

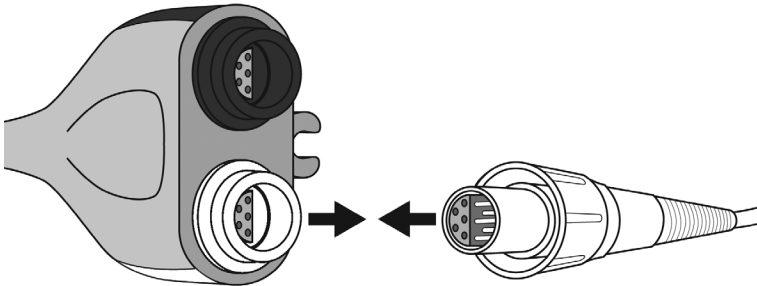



CONNECT

Black to black

White to white

POWERING THE SYSTEM: MPU ALARMS AND TROUBLESHOOTING

ADVISORY

STATUS SYMBOLS	ALARM MEANS	TO RESOLVE ALARM
	Internal fault	<ol style="list-style-type: none"> Promptly connect to two fully charged HeartMate 3™ LVAD 14 V lithium-ion batteries. Call your hospital contact as soon as possible for diagnosis and instructions.
	Replace MPU batteries	Replace the AA batteries in the MPU. 

CHANGING THE ALKALINE AA BATTERIES

1. Loosen the screw from the rear panel.



2. Open the battery compartment and pull the red ribbon to remove the batteries.



3. Place the alkaline AA batteries in the compartment.



4. Close the compartment and tighten the screw.



NOTES

ACCESSORIES

Shower Bag

Keeps the controller and the batteries dry when you shower.

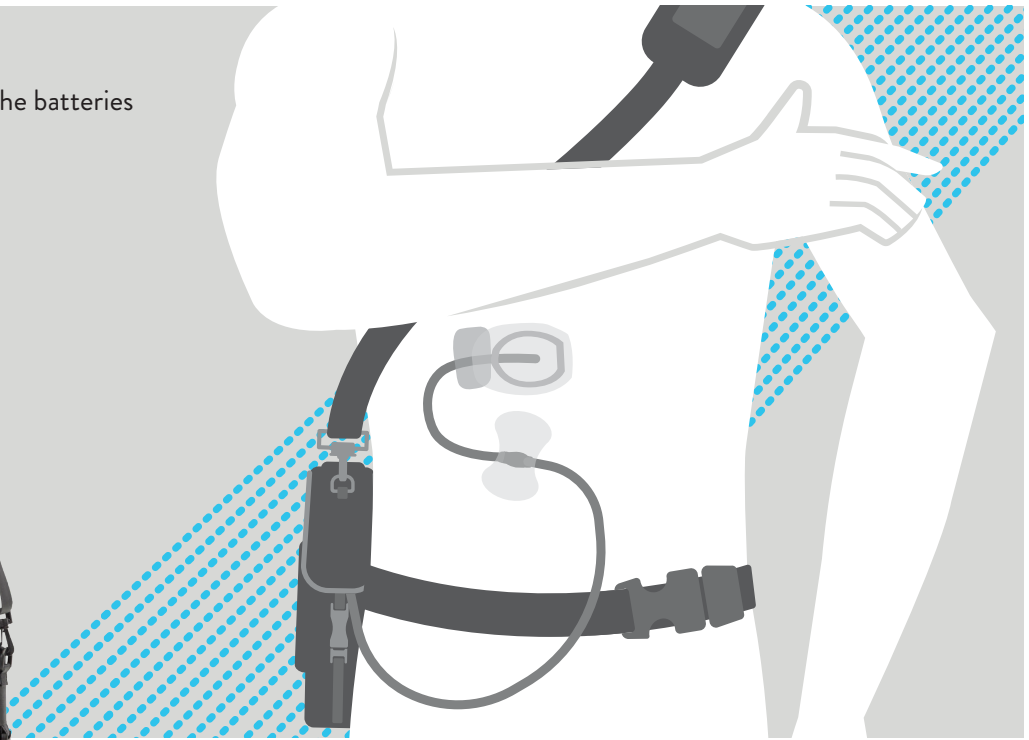

Consolidated Bag

Holds both the controller and the batteries in one bag.



Battery Holster

Allows the batteries to be carried in shoulder straps.



Belt Attachment

An alternative way of wearing the controller.



Holster Vest

A mesh vest that carries the batteries and spreads their weight across the torso.

Abbott

One St. Jude Medical Dr., St. Paul, MN 55117 USA, Tel: 1 651 756 2000
HeartMate3.com

Rx Only**Important Safety Information**

Brief Summary: Prior to using these devices, review the Instructions for Use for a complete listing of indications, contraindications, warnings, precautions, potential adverse events and directions for use.

Indications: The HeartMate 3™ Left Ventricular Assist System is indicated for providing short- and long-term mechanical circulatory support (e.g., as bridge to transplant or myocardial recovery, or destination therapy) in patients with advanced refractory left ventricular heart failure.

Contraindications: The HeartMate 3 Left Ventricular Assist System is contraindicated for patients who cannot tolerate, or who are allergic to, anticoagulation therapy.

Adverse Events: Adverse events that may be associated with the use of the HeartMate 3 Left Ventricular Assist System are: death, bleeding, cardiac arrhythmia, localized infection, right heart failure, respiratory failure, device malfunctions, driveline infection, renal dysfunction, sepsis, stroke, other neurological event (not stroke-related), hepatic dysfunction, psychiatric episode, venous thromboembolism, hypertension, arterial non-central nervous system (CNS) thromboembolism, pericardial fluid collection, pump pocket or pseudo pocket infection, myocardial infarction, wound dehiscence, hemolysis (not associated with suspected device thrombosis) or device thrombosis.

™ Indicates a trademark of the Abbott group of companies.

© 2020 Abbott. All Rights Reserved.

MAT-2002480 v2.0 | Item approved for U.S. use only.

